



Technical Information
TM 315-12

TWIN ASTIR
TWIN ASTIR
TRAINER

Subject: Replacements of Hotellier Quick-links of the control system.

Effectivity: Glider TWIN ASTIR and TWIN ASTIR TRAINER from serial-number 3000 to 3275 including. Steps 3 and 4 from serial-number 3000 to 3291 including.

Accomplishment: Step 1 prior to next flight, after completion every 50 hours until completion of step 2. Step 2 and 3 not later than July 31, 1981. Step 4 is recommended.

Reason: After a high total aircraft time several fractures of 90° quick-connections with open housing (Z-type) due to strong wear and tear were observed at the swivels of the aileron control system which requires the general exchange of the above mentioned joints against those with closed housing and new swivels.

Pages of the manual have to be exchanged that describe the maintenance of links.

Instructions: Step 1. Prior to the next flight and afterwards every 50 hours swivel N° 961 M (detail N° 4) attached to the aileron levers at the root-ribs and the elevator lever must be inspected for wear and tear. Step 1 is not applicable if the elevator push-rod is already equipped with a joint R 9.41. (detail N° 1).

Diameter of the swivel has to be controlled by a micrometer at differences in diameter may not exceed 0.1 mm (0.004 in.) that means the swivel must be spheric.

Tolerances in excess of 0.1 mm (0.004 in.) require step 2 prior to the next flight.

Step 2. Not later than July 31, 1981 all Hotellier Quick-links (swivel and joint) of the aileron control ass'y at the wing mounting and the elevator connection have to be replaced. Step 2 is not applicable to the elevator control ass'y if the elevator push-rod is already equipped with a joint R 9.41. (detail N° 1).

Installed joints R Z 9.41. (open housing) with 9 mm swivel diameter (detail N° 3) of the aileron control ass'y must be replaced by joints R 12.41 (detail N° 2) (normal housing) with 12 mm swivel diameter and installed swivels N° 961 M (detail N° 4) by swivels N° 262 M (detail N° 5).



Technical Information
TM 315-12

TWIN ASTIR
TWIN ASTIR
TRAINER

At the elevator ass'y, if not yet installed, the open-housing-type joint R Z 9.41. (detail N^o. 3) will be replaced by a joint R 9.41. (detail N^o. 1) with normal housing. Swivelsize of 9 mm remains unchanged.

When replacing, the used swivels and also used lock-nuts are removed and new swivels and lock-nuts are installed and locked.

Measure exact adjustment distance and note installation position of joints. Then turn used joints out of the push-rods and install new ones and lock them.

Afterwards check freedom of movement of the partially larger connections with the aircraft rigged. If needed the gaps at the wing roots have to be filed. Friction can be reduced by small adjustments of the installation position.

Deflections of ailerons and elevator must be measured according to maintenance manual and, if needed, adjusted properly.

Note: The installation of stronger links R 12.41. (detail N^o. 2) and swivels N^o.262 M (detail N^o. 5) with a ball-diameter of 12 mm also in the elevator control ass'y is permitted by the aircraft manufacturer.

Step 3. Not later than July 31, 1981 pages 2 and 19 of the maintenance manual have to be replaced that describe maintenance and regular inspections of the connections:

Step 4. Instruction N^o. 4 is an urgent recommendation by the manufacturer and concerns the additional securing of all quick-links of aileron-, elevator- and airbrake ass'ys.

The wedge-type slides of all 5 links at the aircraft have got a control-hole to install a safety-pin when the connection is locked properly.

We urgently recommend that during flying operations all joints are secured additionally by a safety-pin N^o. 500 30 771 (detail N^o. 6). Holes in the slide too small can be drilled to a diameter of 1.5 mm (0.06 in.).

We further advise to tie the safety-pin to the bottom of the link by a short string to avoid the loss of the safety-pin.

Freedom of movements of the connections after installation of safety-pins has to be checked and, if needed, the openings of the root-ribs have to be enlarged.

These securities are designed to give additional confidence in the proper condition of the links and to avoid unintentional disconnecting.

Note: Serial-N^o. 3276 to 3291 only one safety-pin is required (for the elevator).



Technical Information
TM 315-12

TWIN ASTIR
TWIN ASTIR
TRAINER

Material:

1 Manual pg. 2
1 Manual pg. 19
Aileron ass'y:
2 Swivels N°. 262 M
2 Joints R 12.41.
2 Lock-nuts M 6, LN 9348

Elevator ass'y:

1 Swivel N°. 961 M
1 Joint R.9.41.
1 Lock-nut M6, LN 9348
5 Safety-pins N°. 500 34 771

(A. Würth, D-7118 Künzelsau, W.-Germany)

All parts can be ordered from the manufacturer C.O.D. and please, state the total time of your glider when ordering.

**Weight an
balance:**

No change.

Remarks:

The duly execution of these instructions by an experienced and qualified person must be certified by a competent authority in the aircraft's logbook.

Mattsies, May 4, 1981

gez.
i. A. Dipl.-Ing. H. Wilser

LBA acknowledged: June 9, 1981

PS: If you sold your airplane meanwhile, please send this service bulletin to the new owner immediately and inform us about the new address.

Detail N° 1

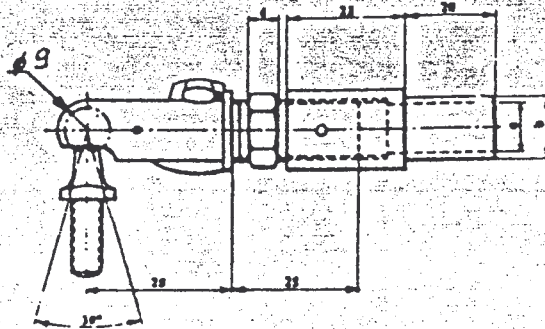

Correct
joint with normal
swivel-housing
R 9.41
for elevator

Detail N° 2

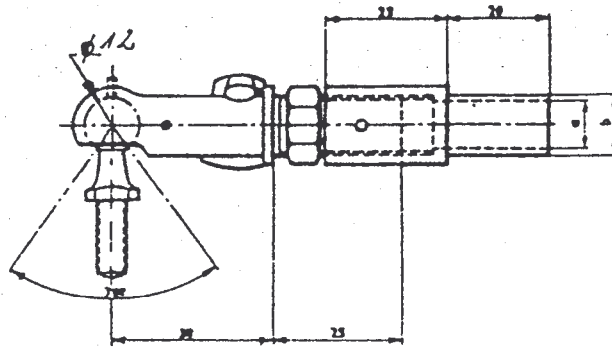

Correct
joint with normal
swivel-housing
R 12.41
for aileron

Detail N° 3

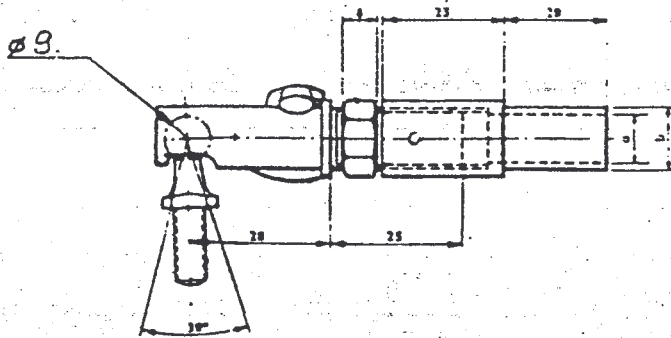

not permitted
joint with open
swivel-housing
(Z-housing)
RZ 9.41.

Detail N° 4

Swivel
N° 961 M
for elevator

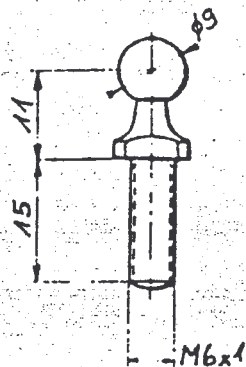

Detail N° 5

Swivel
N° 262 M
for aileron

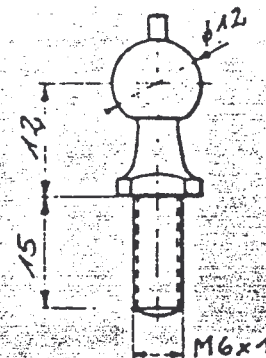

Detail N° 6



Scale 1:1

Safety-pin
N° 500 30 771