

Subject: Modification of the airbrakes

Concerned: G 103C TWIN III ACRO, S/N's 34171 - 34185

Urgency: not later than 31 August 1993

Procedure: Airbrakes with holes in the airbrake plates are installed in the sailplanes with the above S/N's, contrary to the type specification. To assure the airbrake efficiency in the speed range of V_{NE} , a modification to the airbrakes is mandatory.

Actions: The airbrake plates must be modified as follows (hole blanking):

1. Extend airbrakes fully, lock airbrakes and secure against unintentional retraction.
2. Position blanking plates from the front (smaller [1] inboard, larger [2] outboard) on the airbrake plates (10 mm below and 10 mm left or right of the edge of the holes) and secure blanking plates (note the countersunk holes in the blanking plates face forward!).

Note: Do not damage or scratch the surface of the airbrake plates!

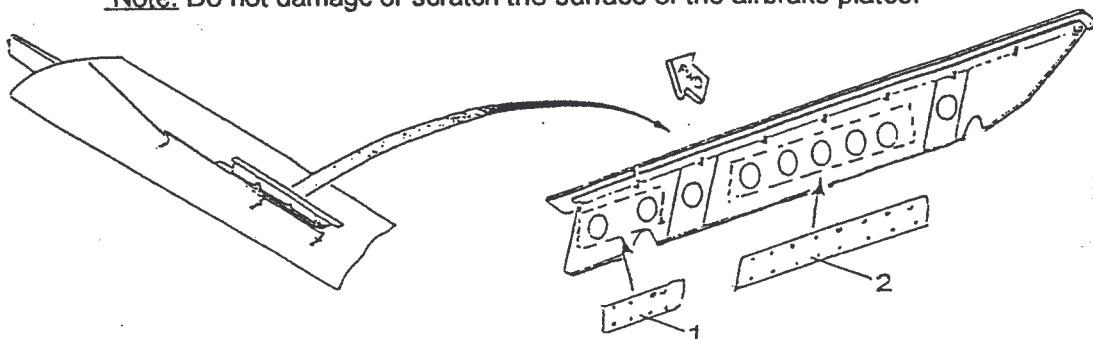

3. Drill the airbrake from the holes in the blanking plates using a 3.1 \varnothing drill. Remove blanking plates and clean.
4. Rivet the blanking plates with aluminium countersunk rivets, size 3x8.
5. Clean airbrake box from swarf and all foreign objects.
6. Perform function test of airbrake control.

Material: The coverplates [1] and [2] and the aluminium rivets [qty. 36] are attached to the Service Bulletin.

Weight and Balance: negligible

Remarks:

1. The modification can be performed by a competent person or an authorized aviation work shop and has to be certified in the logbook by an authorized inspector.
2. If you have sold your sailplane in the meantime, would you kindly pass this information on to the new owner and forward his name and address and aircraft S/N to us.

Mattsies, 26 May 1993

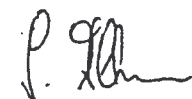
Dipl. Ing. J. Altmann
(Musterprüfleitstelle)

LBA approved:

This Service Bulletin is originally written in German and approved by the German LBA on the ~~May~~ 17.06.93 and is signed by Mr. U. Kopp.

The translation has been accomplished to the best of our knowledge and judgement. In case of doubt, the German original is authoritative.

**Anmerkung zur TM 315-55!
Note to Service Bulletin
TM 315-55!**

zu Maßnahmen Punkt 3 und 4:

- Die Bremsklappenbleche sind mit \varnothing 3,3 mm vorzubohren
- Abdeckbleche mit Nieten, Typ CCR 264CS4-4 annieten.

to Actions, workstep 3 and 4:

- drill the airbrake plates using a 3.3 \varnothing drill
- rivet the blanking plates with rivets, size CCR 264CS4-4

BURKHART GROB Luft- und
Raumfahrt GmbH & Co. KG

**Anmerkung zur TM 315-55!
Note to Service Bulletin
TM 315-55!**

zu Maßnahmen Punkt 3 und 4:

- Die Bremsklappenbleche sind mit \varnothing 3,3 mm vorzubohren
- Abdeckbleche mit Nieten, Typ CCR 264CS4-4 annieten.

to Actions, workstep 3 and 4:

- drill the airbrake plates using a 3.3 \varnothing drill
- rivet the blanking plates with rivets, size CCR 264CS4-4

BURKHART GROB Luft- und
Raumfahrt GmbH & Co. KG