

This Service Bulletin substitutes the Service Bulletin 315-61, dated 06 May 1999.

Subject: Inspection/ Replacement of the knurled nut at the rear control stick

Concerned:

Sailplane Model:	TCDS No. 315
G 103 TWIN II	S/N 3501, - 3729
G 103A TWIN II ACRO	S/N 3501 - 3729 (with suffix "K")

Urgency:

Action 1: before the next flight
Action 2: before the first flight of a day
Action 3: before 31 December 1999

Background Information:

Single cases had been reported to GROB, where the fastening nut (knurled nut) was cracked. Previous investigations showed, that these damages may be caused by improper handling i.e. fastening the nut too tight. As a precautionary action an inspection or replacement of the knurled nut is mandatory.

Actions:

1. The knurled nut must be checked for damage, especially for cracks on the upper side of the nut. **If the nut is found damaged or cracked, the nut must be replaced immediately.**

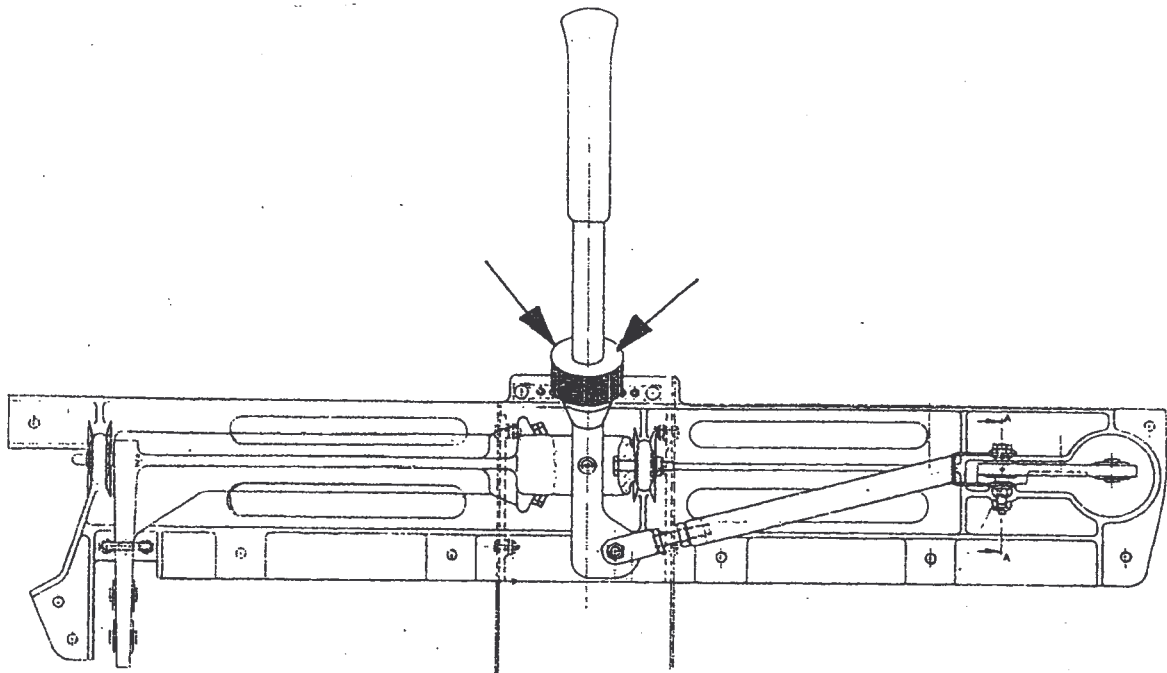

2. The inspection must be repeated before the first flight of a day, until the knurled nut is replaced.
3. The knurled nut at the rear control stick must be replaced for a new knurled nut made from stainless steel.

Material: The new knurled P/N 103-4205.03/2 is attached to the Service Bulletin.

Weight and Balance: not concerned

- Remarks:**
1. The inspection and the replacement of the knurled nut may be performed by a competent person or an authorized aviation work shop and has to be certified in the logbook by an authorized inspector.
 2. If you have sold your sailplane in the meantime, would you kindly pass this information on to the new owner and forward his name and address and aircraft S/N to us.

Mattsies, 28 June 1999



Dipl.Ing. (FH) H. Micheler
Manager
Airworthiness/Certification

LBA approved:

This Service Bulletin is originally written in German and approved by the German LBA on the **06.07.99** 1999. The translation has been accomplished to the best of our knowledge und judgement.

DATUM / DATE	ERSETZT AUSGABE / REPLACES ISSUE	BEARBEITET / PREPARED BY	MUSTERGEPRÜFT / APPROVED BY	SEITE / PAGE
28 June 1999		R. Vodermeier		2 of 2

Subject: Inspection/ Replacement of the knurled nut at the rear control stick

Concerned: Sailplane Model: TCDS No. 315
G 103 TWIN II S/N 3501 - 3729
G 103 TWIN II ACRO S/N 3501 - 3729 (with suffix "K")

Urgency: Action 1: before the next flight
Action 2: before the first flight of a day
Action 3: before 31 December 1999

Background Information: Single cases had been reported to GROB, where the fastening nut (knurled nut) was cracked. Previous investigations showed, that these damages may be caused by improper handling i.e. fastening the nut too tight. As a precautionary action an inspection or replacement of the knurled nut is mandatory.

Actions:

1. The knurled nut must be checked for damage, especially for cracks on the upper side of the nut. **If the nut is found damaged or cracked, the nut must be replaced immediately.**

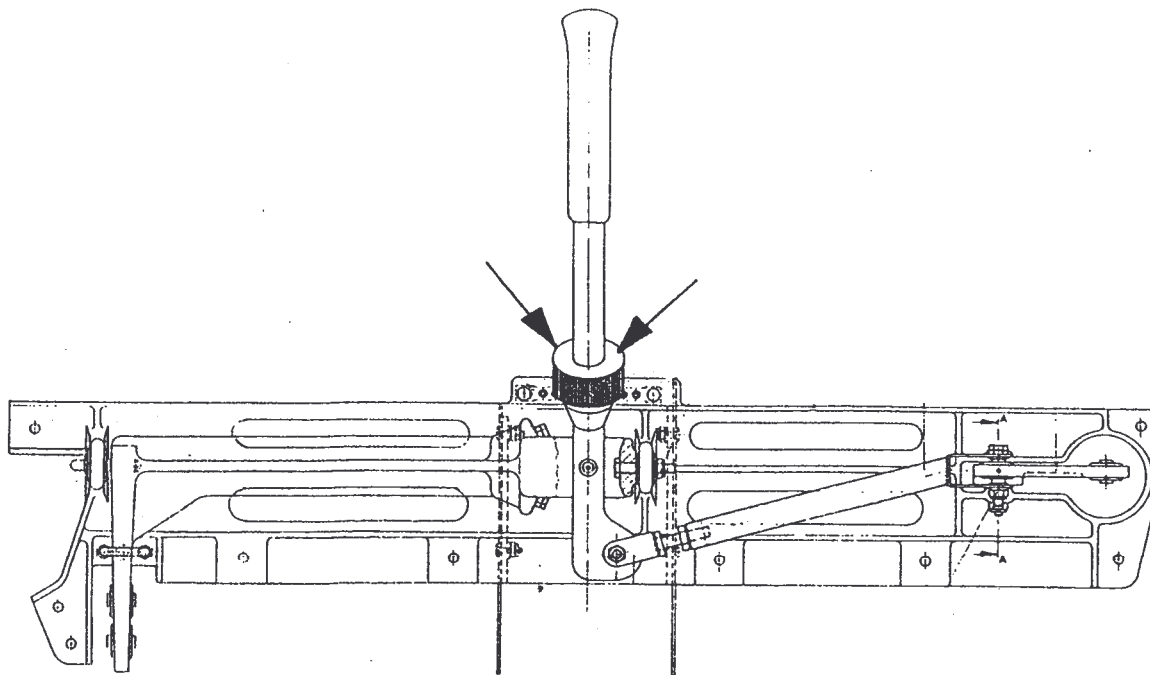

2. The inspection must be repeated before the first flight of a day, until the knurled nut is replaced.
3. The knurled nut at the rear control stick must be replaced for a new knurled nut made from stainless steel.

Material: The new knurled P/N 103-4205.03/2 is attached to the Service Bulletin.

Weight and Balance: not concerned

- Remarks:**
1. The inspection and the replacement of the knurled nut may be performed by a competent person or an authorized aviation work shop and has to be certified in the logbook by an authorized inspector.
 2. If you have sold your sailplane in the meantime, would you kindly pass this information on to the new owner and forward his name and address and aircraft S/N to us.

Mattsies, 06 May 1999

LBA approved:

This Service Bulletin is originally written in German and approved by the German LBA on the 27.05.99 1999. The translation has been accomplished to the best of our knowledge und judgement.



Dipl.Ing. (FH) H. Micheler
Manager
Airworthiness/Certification